



**INSTITUTO DE CIENCIAS
DE LA CONSTRUCCIÓN
EDUARDO TORROJA**

C/ Serrano Galvache n. 4 28033 Madrid (Spain)
Tel.: (34) 91 302 04 40 Fax: (34) 91 302 07 00
direccion.ietcc@csic.es <https://dit.ietcc.csic.es>

European Technical Assessment

ETA 25/1037 of 28/10/2025

English translation prepared by IETcc. Original version in Spanish language

General Part

Technical Assessment Body issuing the ETA designated according to Art. 29 of Regulation (EU) 305/2011:

Instituto de Ciencias de la Construcción Eduardo Torroja (IETcc)

Trade name of the construction product:

Fix master FIXCON PRO concrete screw

Product family to which the construction product belongs:

Screw anchor of sizes 6, 8, 10 and 14 for use in concrete and in precast prestressed hollow core slabs for redundant non-structural systems

Manufacturer:

Ferrometal Oy
Karhutie 9, 01900 Nurmijärvi, Finland
Website: www.ferrometal.fi

Manufacturing plant:

Nurmijärvi plant 1

This European Technical Assessment contains:

18 pages including 4 annexes which form an integral part of this assessment.

This European Technical Assessment is issued in accordance with regulation (EU) No 305/2011, on the basis of:

European Technical Assessment EAD 330747-00-0601 "Fasteners for use in concrete for redundant non-structural systems", ed. May 2018



English translation prepared by IETcc

This European Technical Assessment is issued by the Technical Assessment Body in its official language. Translations of this European Technical Assessment in other languages shall fully correspond to the original issued document and should be identified as such.

This European Technical Assessment may be withdrawn by the issuing Technical Assessment Body, in particular pursuant to information by the Commission according to article 25 (3) of Regulation (EU) No 305/2011.

INFORME DE FIRMA, no sustituye al documento original | C.S.V. : GEN-8ae1-0263-21af-6cdc-51f1-a981-b7e5-6d80 | Puede verificar la integridad de este documento en la siguiente dirección: <https://run.gob.es/hsbIF8yLcR>

CSV : GEN-8ae1-0263-21af-6cdc-51f1-a981-b7e5-6d80

DIRECCIÓN DE VALIDACIÓN : <https://run.gob.es/hsbIF8yLcR>

FIRMANTE(1) : ANGEL CASTILLO TALAVERA | FECHA : 07/11/2025 19:09 | Sin acción específica



SPECIFIC PART

1. Technical description of the product

The **Fix master FIXCON PRO concrete screw** is a fastener made of carbon steel of sizes 6,8,10 and 14. The fastener is installed into a predrilled cylindrical drilled hole. The special thread of the fastener cuts an internal thread into the concrete member while setting. The anchorage is characterised by mechanical interlock between fastener and concrete.

Product and installation descriptions are given in annex A.

2. Specification of the intended use in accordance with the applicable European Assessment Document.

The performances given in section 3 are only valid if the anchor is used in compliance with the specifications and conditions given in annex B.

The verifications and assessment methods on which this European Technical Assessment is based, lead to the assumption of a working life of the anchor of at least 50 years. The indications given on the working life cannot be interpreted as a guarantee given by the producer, but are to be regarded only as a mean to choosing the right products in relation to the expected economically reasonable working life of the works.

3. Performance of the product and references to the methods used for its assessment

3.1 Safety in case of fire (BWR 2)

Essential characteristic	Performance
Reaction to fire	Anchorage satisfy requirements for class A1 according to EN 13501-7
Resistance to fire	See annex D

3.2 Safety in use (BWR 4)

Essential characteristic	Performance
Characteristic resistance under static or quasi static loading	See annex C

4. Assessment and Verification of Constancy of Performance (hereinafter AVCP) system applied, with reference to its legal base

The applicable European legal act for the system of Assessment and Verification of Constancy of Performance (see annex V to Regulation (EU) No 305/2011) is 97/161/EC.

The system to be applied is 2+.



English translation prepared by IETcc

5. Technical details necessary for the implementation of the AVCP system, as provided for in the applicable European Assessment Document.

The technical details necessary for the implementation of the AVCP system are laid down in the quality plan deposited at Instituto de Ciencias de la Construcción Eduardo Torroja.

Prepared by: Julián Rivera Lozano (Innovative Products Assessment Unit, IETcc – CSIC)



Instituto de Ciencias de la Construcción Eduardo Torroja
CONSEJO SUPERIOR DE INVESTIGACIONES CIENTÍFICAS

















C/ Serrano Galvache n.º 4. 28033 Madrid.
Tel: (+34) 91 302 04 40 Fax. (+34) 91 302 07 00
<https://dit.ietcc.csic.es>



On behalf of the Instituto de Ciencias de la Construcción Eduardo Torroja
Madrid, 28th of October 2023

Director IETcc - CSIC



Product and identification		
		HHW
		RH
		PH
		CH
		HH
		HHH
		TH
		THU
Fix master FIXCON PRO concrete screw		Annex A1
Product description		
Identification		




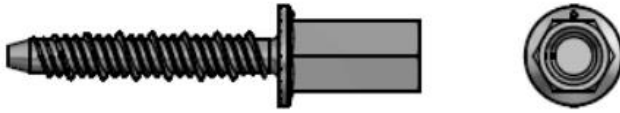



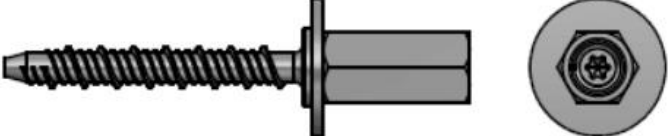


	CTH
	IT
	FHC
	HHC
	HHCT
	SFN
	SSFN
	SFCN
Fix master FIXCON PRO concrete screw	
Product description Identification	Annex A2

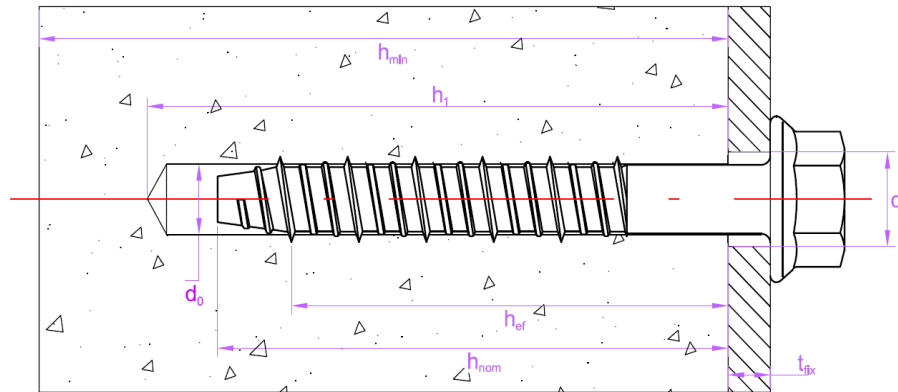


Table A1: Materials

Item	Designation	Fix master FIXCON PRO concrete screw
1	Anchor Body	Carbon steel wire rod cold forged. Allowed coatings: <ul style="list-style-type: none"> • Zinc plated ISO 4042 • Silver ruspert • Zinc flake EN 10683 • Mechanical galvanizing

Installed condition

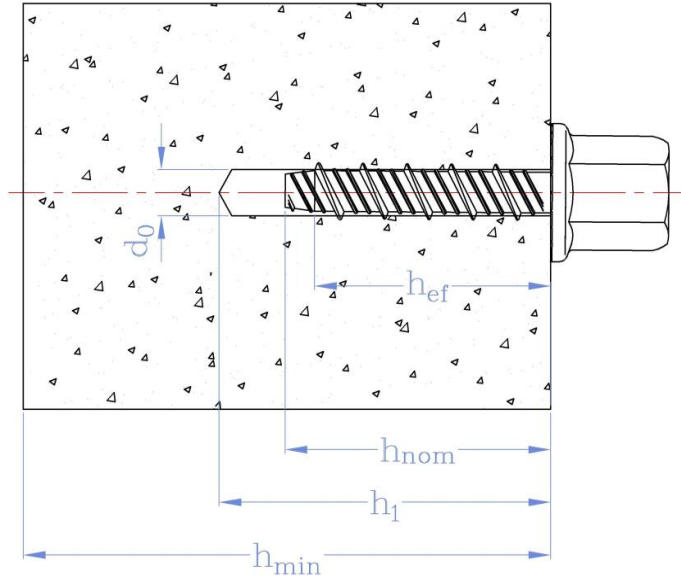
- h_{ef} : Effective anchorage depth
- h_1 : Depth of drilled hole
- h_{nom} : Overall anchor embedment depth in the concrete
- h_{min} : Minimum thickness of concrete member
- t_{fix} : Thickness of fixture
- d_0 : Nominal diameter of drill bit
- d_r : Diameter of clearance hole in fixture



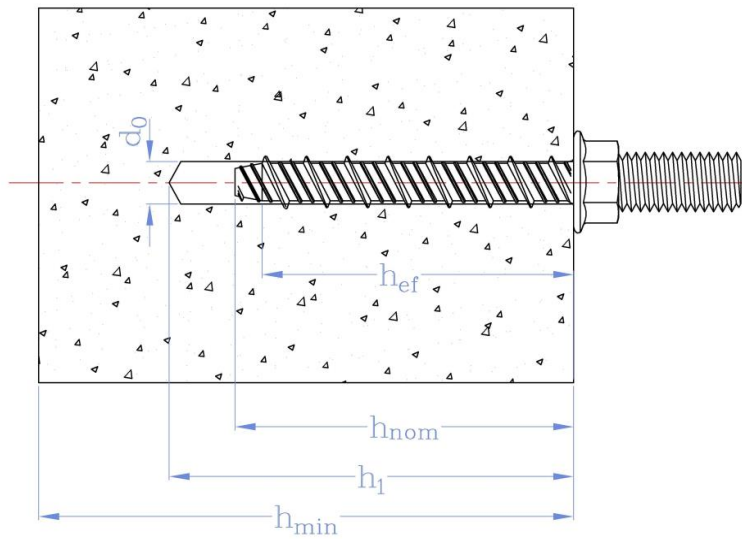
Drawing A1. Installed condition in normal weight concrete for anchors HHW, RH, PH, CH, HH, HHH, TH and THU.

Fix master FIXCON PRO concrete screw	Annex A4
Product description	
Materials and installed condition in concrete	





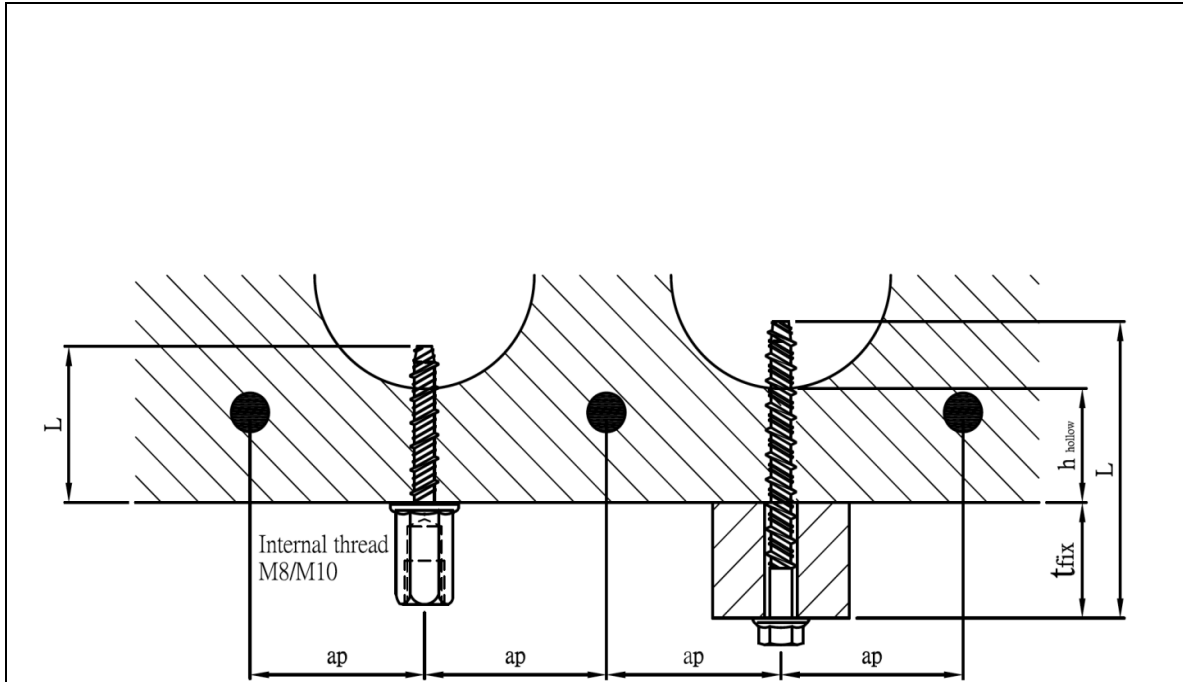
Drawing A2. Installed condition for anchors CTH, IT, FHC, HHC, HHCT, SFN, SSFN, SFCN and HHB



Drawing A3. Installed condition for anchors CTH, IT, FHC, HHC, HHCT, SFN, SSFN, SFCN and HHB

Fix master FIXCON PRO concrete screw	Annex A5
Product description	
Installed condition in concrete	





Drawing A4. Installed condition in prestressed hollow core concrete slabs

- ap: Distance between anchor position and prestressing steel (≥ 50 mm).
 L: Screw anchor length
 h_{hollow} : Thickness of hollow core concrete slab ≥ 25 mm
 t_{fix} : Fixture thickness ($\geq L - h_{\text{hollow}}$, where $h_{\text{hollow}} = 25$ mm if h_{hollow} is unknown)
 w: Core width
 e: Web thickness

Note that $w/e \leq 4,2$

Fix master FIXCON PRO concrete screw

Product description

Installed condition in prestressed hollow core concrete slabs

**Annex
A6**



Specifications of intended use

Anchorage subjected to:

- Static or quasi static loads for redundant non-structural systems
- Use for anchorages with requirements related to resistance of fire (not for using in prestressed hollow core slabs)
- The anchor may only be used if in the design and installation specifications for the fixture the excessive slip or failure of one anchor will not result in a significant violation of the requirements on the fixture in the serviceability and ultimate state.

Base materials:

- Reinforced or unreinforced normal weight concrete according to EN 206:2013.
- Strength classes C20/25 to C50/60 according to EN 206:2013.
- Cracked or uncracked concrete.
- Precast, prestressed hollow core concrete slabs, strength C30/37 according to EN 206:2013

Use conditions (environmental conditions):

- Anchorages subjected to dry internal conditions.

Design:

- Anchorages are designed under the responsibility of an engineer experienced in anchorages and concrete work.
- Verifiable calculation rules and drawings are prepared taking into account of the loads to be anchored. The position of the fastener is indicated on the design drawings (e.g. position of the fastener relative to reinforcement or to supports, etc.).
- Anchorages under static or quasi-static actions are designed for design method A in accordance with EN 1992-4:2018.
- Anchorages under fire exposure are designed in accordance with EN 1992-4:2018. It must be ensured that local spalling of the concrete cover does not occur.

Installation:

- Hole drilling by rotary plus hammer mode.
- Fastener installation carried out by appropriately qualified personal and under the supervision of the person responsible for technical matters of the site.
- In case of aborted hole: new drilling at a minimum distance away of twice the depth of aborted hole or smaller distance if the aborted hole is filled with high strength mortar and if under shear or oblique tension load it is not the direction of the load application.
- After installation further turning of the anchor must not be possible.
- The head of the fastener must be supported on the fixture and is not damaged.
- In precast pre-stressed hollow core slabs, the screw may be installed from all directions, if the web thickness and the spacing to the tensioning strands are defined according to Table B2
- Shear assessment only covers the shear force induced by the fixtured piece, i.e. the piece located between the anchor head and the concrete block (piece contained in t_{fix} , see Drawings A1 and A4).

Fix master FIXCON PRO concrete screw

Intended use

Specifications

**Annex
B1**



Table B1: Installation parameters in concrete

Installation parameters		Performance				
		6	8	10	14	
d_0	Nominal diameter of drill bit: [mm]	6	6	8	10	14
d_f	Diameter of clearance hole in fixture: [mm]	9	9	12	14	18
d_s	Outer diameter of the thread [mm]	7,5	7,5	10,5	12,5	16,5
L_{min}	Total length of the anchor (L) [mm]	40	55	50	60	75
L_{max}		400	400	400	400	400
h_{min}	Minimum thickness of concrete member: [mm]	80	90	90	100	120
h_1	Depth of drilled hole: [mm]	L+10	L+10	L+10	L+10	L+15
h_{nom}	Overall anchor embedment depth in the concrete: [mm]	40	55	50	60	75
h_{ef}	Effective anchorage depth: [mm]	29	42	37	44	56
T_{ins}	Installation torque [Nm]	15	15	25	50	80
t_{fix}	Thickness of fixture [mm]	L-40	L-55	L-50	L-60	L-75
s_{min}	Minimum allowable spacing: [mm]	35	35	35	50	75
c_{min}	Minimum allowable edge distance: [mm]	35	35	35	40	45

Table B2: Installation parameters in prestressed hollow core concrete slabs

Installation parameters		Performance		
		6		
d_0	Nominal diameter of drill bit: [mm]	6		
d_f	Diameter of clearance hole in fixture: [mm]	9		
d_s	Outer diameter of the thread [mm]	7,5		
L_{min}	Total length of the anchor (L) [mm]	$> h_{hollow}$		
L_{max}		400		
h_{hollow}	Minimum concrete thickness with hollow [mm]	35	30	25
h_{ef}	Effective anchorage depth: [mm]	27	23	19
T_{ins}	Installation torque [Nm]	15		
t_{fix}	Thickness of fixture [mm]	$\geq L - 35$	$\geq L - 30$	$\geq L - 25$
s_{min}	Minimum allowable spacing: [mm]	100		
c_{min}	Minimum allowable edge distance: [mm]	100		

Fix master FIXCON PRO concrete screw

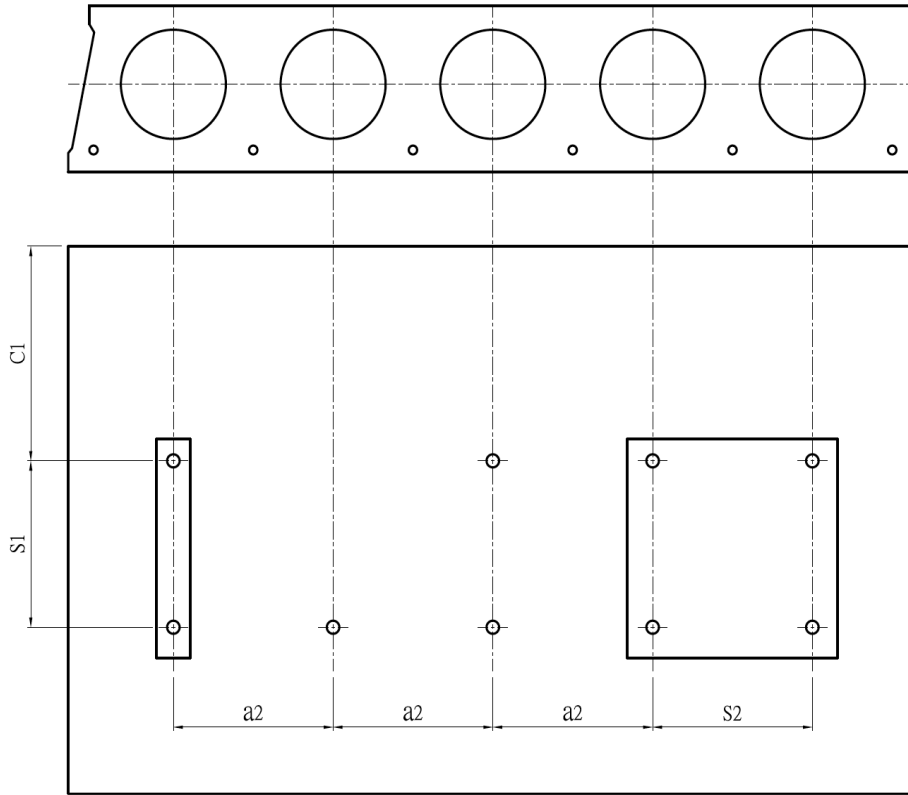
Performances

Installation parameters and installation procedure

**Annex
B2**



Installation process in prestressed hollow core concrete slabs



Drawing B3. Installation parameter for anchorage in precast prestressed hollow core slabs

- C_1, C_2 : Edge distance
- S_1, S_2 : Anchor spacing
- a_1, a_2 : Distance between anchor groups
- C_{min} : Minimum edge distance ≥ 100 mm
- S_{min} : Minimum anchor spacing ≥ 100 mm
- a_{min} : Minimum distance between anchor groups ≥ 100 mm

Fix master FIXCON PRO concrete screw

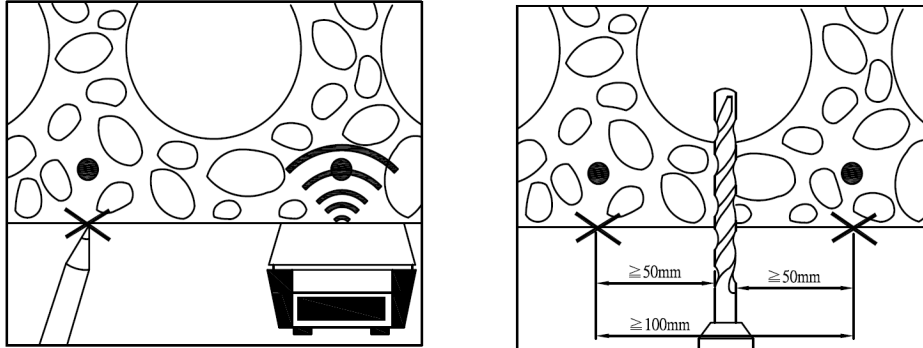
Performances

Installation parameters and installation procedure

**Annex
B3**

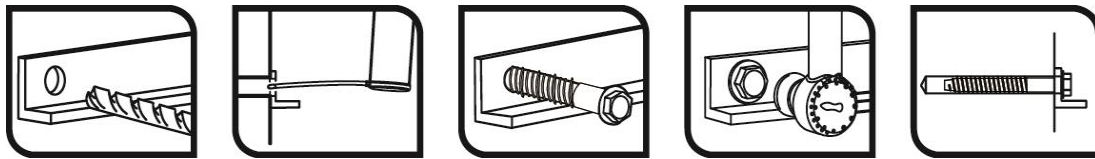


Drawing B4 shows the installation steps for prestressed hollow core concrete slabs. Firstly, determine and mark positions of the tensioning strands, and then keep distance.



Drawing B4. Installation process in prestressed hollow core concrete slabs

Installation process



Drawing B5. Installation process

Anchor shall be installed using a torque wrench or an electrical impact driver; power input: 500 W; torque: 50-250 Nm. (e.g: Bosch GDS 18E)

Fix master FIXCON PRO concrete screw

Performances

Installation parameters and installation procedure

**Annex
B4**



Table C1: Characteristic values to tension loads of design method A according to EN 1992-4

Characteristic values of resistance to tension loads of design method A		Performance				
		6	8	10	14	
h_{nom}	Nominal embedment depth: [mm]	40	55	50	60	75
Tension loads: steel failure						
$N_{Rk,s}$	Tension steel characteristic resistance: [kN]	18,6	18,6	32,6	51,2	115,8
γ_{Ms}	Partial safety factor: ¹⁾ [-]	1,5				
Tension loads: pull-out failure in concrete						
$N_{Rk,p}$	Characteristic resistance in concrete C20/25: [kN]	4,0	2)			
ψ_c	C30/37 [-]	1,16	1,16	1,16	1,14	1,13
	C40/45 [-]	1,29	1,29	1,28	1,25	1,24
	C50/60 [-]	1,40	1,40	1,39	1,34	1,33
Tension loads: concrete cone and splitting failure						
h_{ef}	Effective embedment depth: [mm]	29	42	37	44	56
$k_{ucr,N}$	Factor for uncracked concrete: [-]	11,0				
$k_{cr,N}$	Factor for cracked concrete: [-]	7,7				
$s_{cr,N}$	Critical spacing (concrete cone failure): [mm]	3,0 x h_{ef}				
$c_{cr,N}$	Critical edge distance (concrete cone failure): [mm]	1,5 x h_{ef}				
$s_{cr,sp}$	Critical spacing (splitting failure): [mm]	87	126	111	132	168
$c_{cr,sp}$	Critical edge distance (splitting failure): [mm]	44	63	56	66	84
γ_{inst}	Robustness: [-]	1,2	1,2	1,2	1,2	1,2

¹⁾ In absence of other national regulations

²⁾ Pull-out failure is not decisive

Table C2: Characteristic values to shear loads of design method A according to EN 1992-4

Characteristic values of resistance to shear loads of design method A		Performance				
		6	8	10	14	
h_{nom}	Nominal embedment depth: [mm]	40	55	50	60	75
Shear loads: steel failure without lever arm						
$V_{Rk,s}$	Characteristic resistance: [kN]	9,3	16,3	25,6	57,9	
k_7	Ductility factor: [-]	0,80	0,80	0,80	0,80	
γ_{Ms}	Partial safety factor: ¹⁾ [-]	1,25				
Shear loads: steel failure with lever arm						
$M^0_{Rk,s}$	Characteristic bending moment: [Nm]	15,2	35,3	69,3	235,9	
γ_{Ms}	Partial safety factor: ¹⁾ [-]	1,25				
Shear loads: concrete pry-out failure						
k_8	Pry-out factor: [-]	0,8	1,2	1,0	1,6	
γ_{inst}	Installation safety factor: ¹⁾ [-]	1,0				
Shear loads: concrete edge failure						
l_f	Effective anchorage depth under shear loads: [mm]	29	37	44	56	
d_{nom}	Outside anchor diameter: [mm]	6	8	10	14	
γ_{inst}	Installation safety factor: ¹⁾ [-]	1,2				

¹⁾ In absence of other national regulations

Fix master FIXCON PRO concrete screw

Performances

Characteristic values for tension and shear force in concrete

**Annex
C1**



Table C3: Characteristic values to tension loads in precast, prestressed hollow core slabs C30/37 of design method A according to EN 1992-4

Characteristic values of resistance to tension loads of design method A		Performance		
		6		
h_{nom}	Nominal embedment depth: [mm]	35		
Tension loads: steel failure				
$N_{Rk,s}$	Tension steel characteristic resistance: [kN]	18,7		
γ_{Ms}	Partial safety factor: ¹⁾ [-]	1,5		
Tension loads: pull-out failure in concrete				
$N_{Rk,p}$	Characteristic resistance in concrete C30/37: [kN]	3,5	4,0	4,5
Tension loads: concrete cone and splitting failure				
h_{hollow}	Minimum thickness of concrete member: [mm]	25	30	35
$k_{ucr,N}$	Factor for uncracked concrete: [-]	11,0		
$k_{cr,N}$	Factor for cracked concrete: [-]	7,7		
$s_{cr,N}$	Critical spacing (concrete cone failure): [mm]	3,0 x h_{ef}		
$c_{cr,N}$	Critical edge distance (concrete cone failure): [mm]	1,5 x h_{ef}		
$s_{cr,sp}$	Critical spacing (splitting failure): [mm]	87		
$c_{cr,sp}$	Critical edge distance (splitting failure): [mm]	44		
γ_{inst}	Robustness: [-]	1,2		

¹⁾ In absence of other national regulations

Table C4: Characteristic values to shear loads in precast, prestressed hollow core slabs C30/37 of design method A according to EN 1992-4

Characteristic values of resistance to shear loads of design method A		Performance		
		6		
h_{nom}	Nominal embedment depth: [mm]	35		
Shear loads: steel failure without lever arm				
$V_{Rk,s}$	Characteristic resistance: [kN]	10		
k_7	Ductility factor: [-]	0,8		
γ_{Ms}	Partial safety factor: ¹⁾ [-]	1,25		
Shear loads: steel failure with lever arm				
$M^0_{Rk,s}$	Characteristic bending moment: [Nm]	15,2		
γ_{Ms}	Partial safety factor: ¹⁾ [-]	1,25		
Shear loads: concrete pry-out failure				
k_8	Pry-out factor: [-]	1,0		
γ_{inst}	Installation safety factor: ¹⁾ [-]	1,0		
Shear loads: concrete edge failure				
l_f	Effective anchorage depth under shear loads: [mm]	29		
d_{nom}	Outside anchor diameter: [mm]	6		
γ_{inst}	Installation safety factor: ¹⁾ [-]	1,2		

¹⁾ In absence of other national regulations

Fix master FIXCON PRO concrete screw

Performances

Characteristic values for tension and shear force in prestressed hollow core slabs

Annex
C2



Table D1: Characteristic values to fire resistance

Fire resistance duration = 30 minutes		6	8	10	14
Tension loads, steel failure					
$N_{Rk,s,fi,30}$	Characteristic resistance [kN]	0.23	0.61	1.28	2.90
Pull-out failure					
$N_{Rk,p,fi,30}$	Character. resistance in concrete C20/25 to C50/60 [kN]	1.50	2.25	3.00	7.50
Concrete cone failure **)					
$N_{Rk,c,fi,30}$	Character. resistance in concrete C20/25 to C50/60 [kN]	2.06	2.45	3.51	12.35
Shear loads steel failure without lever arm					
$V_{Rk,s,fi,30}$	Characteristic resistance [kN]	0.23	0.61	1.28	2.90
Shear loads, steel failure with lever arm					
$M_{Rk,s,fi,60}$	Characteristic bending resistance [Nm]	0.19	0.66	1.73	5.90

Fire resistance duration = 60 minutes		6	8	10	14
Tension loads, steel failure					
$N_{Rk,s,fi,60}$	Characteristic resistance [kN]	0.21	0.53	0.96	2.17
Pull-out failure					
$N_{Rk,p,fi,60}$	Character. resistance in concrete C20/25 to C50/60 [kN]	1.50	2.25	3.00	7.50
Concrete cone failure **)					
$N_{Rk,c,fi,60}$	Character. resistance in concrete C20/25 to C50/60 [kN]	2.06	2.45	3.51	12.35
Shear loads, steel failure without lever arm					
$V_{Rk,s,fi,60}$	Characteristic resistance [kN]	0.21	0.53	0.96	2.17
Shear loads, steel failure with lever arm					
$M_{Rk,s,fi,60}$	Characteristic bending resistance [Nm]	0.17	0.57	1.30	4.42

Fire resistance duration = 90 minutes		6	8	10	14
Tension loads, steel failure					
$N_{Rk,s,fi,90}$	Characteristic resistance [kN]	0.16	0.41	0.83	1.88
Pull-out failure					
$N_{Rk,p,fi,90}$	Character. resistance in concrete C20/25 to C50/60 [kN]	1.50	2.25	3.00	7.50
Concrete cone failure **)					
$N_{Rk,c,fi,90}$	Character. resistance in concrete C20/25 to C50/60 [kN]	2.06	2.45	3.51	12.35
Shear loads, steel failure without lever arm					
$V_{Rk,s,fi,90}$	Characteristic resistance [kN]	0.16	0.41	0.83	1.88
Shear loads, steel failure with lever arm					
$M_{Rk,s,fi,90}$	Characteristic bending resistance [Nm]	0.13	0.44	1.13	3.83

Fix master FIXCON PRO concrete screw

Performances

Characteristic values for resistance to fire in concrete

**Annex
D1**



English translation prepared by IETcc

Fire resistance duration = 120 minutes		6	8	10	14
Tension loads, steel failure					
$N_{Rk,s,fi,120}$	Characteristic resistance [kN]	0.12	0.33	0.64	1.45
Pull-out failure					
$N_{Rk,p,fi,120}$	Character. resistance in concrete C20/25 to C50/60 [kN]	1,20	1.80	2.40	6.00
Concrete cone failure **)					
$N_{Rk,c,fi,120}$	Character. resistance in concrete C20/25 to C50/60 [kN]	1.65	1.96	2.81	9.88
Shear loads, steel failure without lever arm					
$V_{Rk,s,fi,120}$	Characteristic resistance [kN]	0.12	0.33	0.64	1.45
Shear loads, steel failure with lever arm					
$M_{Rk,s,fi,120}$	Characteristic bending resistance [Nm]	0.10	0.35	0.87	2.95

Spacing and edge distances		6	8	10	14
$S_{cr,N}$	Spacing [mm]	168	180	208	344
S_{min}	Minimum spacing [mm]	45	50	60	100
$C_{cr,N}$	Edge distance [mm]	84	90	104	172
C_{min}	Minimum edge distance (one side fire) [mm]	84	90	104	172
C_{min}	Minimum edge distance (two sides fire) [mm]	300	300	300	300
γ_{Msp}	Partial safety factor ¹⁾ [-]	1.0	1.0	1.0	1.0

*) In absence of other national regulations
**) As a rule, splitting failure can be neglected when cracked concrete and reinforcement is assumed.

Concrete pry-out failure		6	8	10	14
k factor	[-]	1	1	1	2

According to EN 1992-4:2018, these values of k factor and the relevant values of $N_{Rk,c,fi}$ given in the above tables have to be considered in the design.

Concrete edge failure	
The characteristic resistance $V_{Rk,c,fi}^0$ in C20/25 to C50/60 concrete is determined by: $V_{Rk,c,fi}^0 = 0.25 \times V_{Rk,c}^0 (\leq R90)$ and $V_{Rk,c,fi}^0 = 0.20 \times V_{Rk,c}^0 (R120)$ With $V_{Rk,c}^0$ initial value of the characteristic resistance in cracked concrete C20/25 under normal temperature according to EN 1992-4:2018.	

Fix master FIXCON PRO concrete screw	Annex D2
Performances	
Characteristic values for resistance to fire in concrete	

